

VX-601

Quick Start Guide



Connector Power

VX-601 allows a wide range of DC power input from 9~60V via a 4-pin circular power code.

Power source from car power

1. The bare wire lead cable allows you to directly wire 12 V, 24 V, 36V and 48V power cable or adapters.

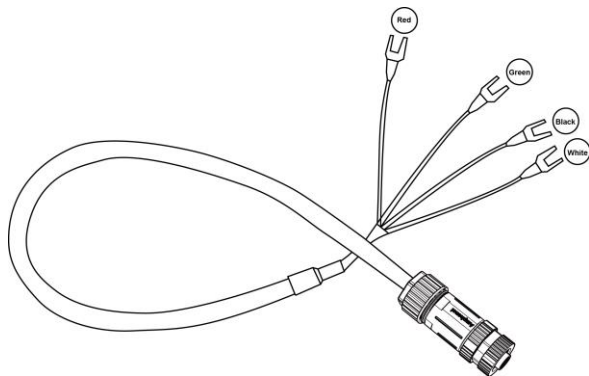

Connector Power

Please follow the wire definition below to connect to your power source.

Wire Color	Description
RED	V+
BLACK	V-
GREEN	Chassis Ground
WHITE	ACC/ Ignition

2. Plug the power code into the power connector facing the top of the arrow mark.

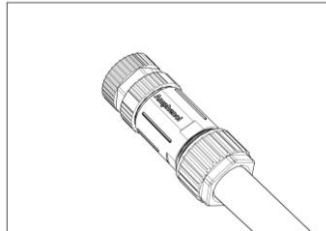

3. Twist the nut to lock the power connector to the device.

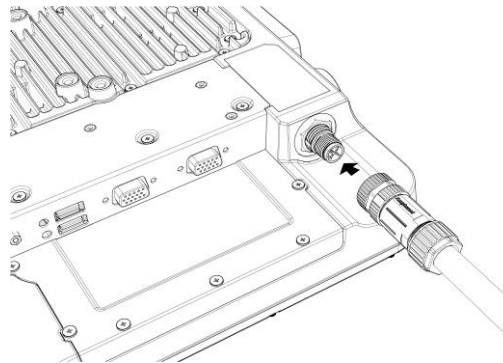

Power Source from external power adapter

If your power source is from external power adapter, your power source will not be controlled by ACC/Ignition signal. Please short red(V+) and white(ACC/Ignition) wires.

Power on the System

VX601 has two power modes for user preference which can be activated through DashON. If you want to use power source via power adapter, please disable “ACC Input Detection”.

To turn on the system, please follow the directions below:

1. Press power button to turn on the system
2. When VX-601 is in “Non-ACC mode”, the device will not auto power off when the power supply is removed (charged from UPS battery instead), please use windows command to fully shut down the device.
3. When VX-601 is in “ACC Sense Mode”, please follow the directions below:
 - When the system is Off, switch the ignition from Off to On, the system will turn on/delay on.
 - When the system is Off and the ignition is Off, press the power button, the system will be turned on/no delay on.
 - When System is Off and the ignition is On, press the power button, the system will be turned on/no delay on.

LED Indicators

LED	Status	Description
System	Blink Green	Power up
System	Blink Amber	Load BIOS/ boot loader
System	Solid Green	System ready for use
System	Blink Red	Abnormal vehicle battery
Battery	Slow Blink Orange	Charging
Battery	Off (No light)	Discharging
Battery	Solid Orange	Full Charged
Display/Defrost	Solid Green	Function turn on/defrost function mark (defrost LED light will only be present for defrost versions)
LED	Status	Description
WWAN	Solid Green	Module enabled
WIFI	Solid Green	Module enabled
BT	Solid Green	Module enabled



Ensure that the power supplies are disconnected when the power cord is plugged into the power connector.



Lithium Battery Safety Statement

WARNING: Do not expose the battery to excessive heat source, such as fire, direct sunlight, etc.

Caution: Lithium battery inside. Danger of explosion if battery is incorrectly replaced.

Replace only with the same or equivalent type recommended by the battery manufacturer.

THIS PRODUCT CONTAINS LITHIUM-ION BATTERY PACKS. IT MUST BE DISPOSED PROPERLY.

CONTACT YOUR LOCAL ENVIRONMENTAL AGENCIES FOR INFORMATION ON PROPER RECYCLING AND DISPOSAL.

Install M.2 SSD Storage

Please follow the instructions to install your M.2 model:

1. Shut down the system properly and disconnect the device from all power sources.
2. Un-mount the device from the mounting apparatus; make sure that the display surface is protected.
3. Remove the screws and the service cover.

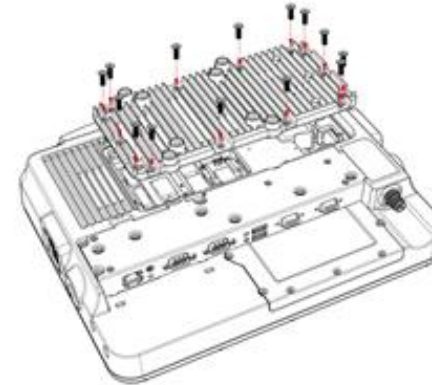

4. Locate the M.2 module slot; see the following image.

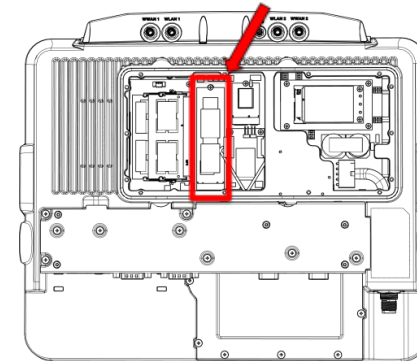

5. Insert the M.2 module into the slot and then fasten the screws or loosen the screws to remove the card
6. Replace the service cover