



VIKING

Mobile Data Terminal

User's Manual



v1.1



Contents

CONTENTS	2
SAFETY PRECAUTIONS	4
REGULATORY AND CERTIFICATION	6
FCC.....	6
RF EXPOSURE WARNING.....	7
CE MARKING.....	7
LITHIUM BATTERY SAFETY STATEMENT	10
CHAPTER 1. PRODUCT INTRODUCTION	11
HARDWARE SPECIFICATIONS.....	11
ENVIRONMENT.....	12
I/O PORTS.....	13
DIMENSION AND WEIGHT	14
VIKING Standard.....	14
PACKAGE LIST	15
CHAPTER 2. HARDWARE INSTALLATION	16
INSTALLING/REMOVING THE SIM CARD	16
Internal SIM slot (SIM2).....	16
External SIM slot (SIM1)	18
CHAPTER 3. HARDWARE MOUNTING	19
CHAPTER 4. START UP	20
POWERING THE SYSTEM.....	20
Installation Instructions.....	20
Connector Power	21
Backup Battery.....	23
Powering Down the System.....	24
Unexpected Power Outage	24
LED STATUS.....	25
ADJUST THE SPEAKER VOLUME	26
AUTO-BRIGHTNESS ADJUSTMENT	26

INTERNAL MICROPHONE.....	27
PROGRAMMABLE BUTTONS.....	27
POWER MANAGEMENT.....	27
CHAPTER 5. JUMPERS AND CONNECTORS	28
BOTTOM VIEW	28
EXTERNAL CONNECTORS PIN ASSIGNMENTS.....	29
Power Connector.....	29
RS-232 Port (COM1).....	30
USB and RS-232/422/485 Port (COM2).....	31
Digital I/O and CANbus Port.....	33
CHAPTER 6. TECHNICAL SUPPORT	34

Safety Precautions

1. Read these safety instructions carefully.
2. Keep this user's manual for later reference.
3. Disconnect this equipment from any outlet before cleaning. Use a damp cloth. Do not use liquid or spray detergents for cleaning.
4. For plug-in equipment, the power outlet socket must be located near the equipment and must be easily accessible.
5. Keep this equipment away from humidity.
6. Put this equipment on a stable surface during installation. Dropping it or letting it fall may cause damage.
7. Do not leave this equipment in either an unconditioned environment or in an above 40°C storage temperature as this may damage the equipment.
8. Make sure the voltage of the power source is correct before connecting the equipment to the power outlet.
9. Place the power cord in a way so that people will not step on it. Do not place anything on top of the power cord. Use a power cord that has been approved for use with the product and that it matches the voltage and current marked on the product's electrical range label. The voltage and current rating of the cord must be greater than the voltage and current rating marked on the product.
10. All cautions and warnings on the equipment should be noted.
11. If the equipment is not used for a long time, disconnect it from the power source to avoid damage by transient overvoltage.
12. Never pour any liquid into an opening. This may cause fire or electrical shock.
13. Never open the equipment. For safety reasons, the equipment should be opened only by qualified service personnel.
14. If one of the following situations arise, get the equipment checked by service personnel:
 - a. The power cord or plug is damaged.
 - b. Liquid has penetrated into the equipment.
 - c. The equipment has been exposed to moisture.
 - d. The equipment does not work well, or you cannot get it to work according to the user's manual.
 - e. The equipment has been dropped and damaged.

- f. The equipment has obvious signs of breakage.
- 15. Do not place heavy objects on the equipment.
- 16. The unit uses a three-wire ground cable which is equipped with a third pin to ground the unit and prevent electric shock. Do not defeat the purpose of this pin. If your outlet does not support this kind of plug, contact your electrician to replace your obsolete outlet.
- 17. **CAUTION: DANGER OF EXPLOSION IF BATTERY IS INCORRECTLY RE- PLACED. REPLACE ONLY WITH THE SAME OR EQUIVALENT TYPE REC- OMMENDED BY THE MANUFACTURER. DISCARD USED BATTERIES ACCORDING TO THE MANUFACTURER'S INSTRUCTIONS.**

Regulatory and Certification

FCC

This device complies with Part 15 of the FCC Rules. Operation is subject to the following two conditions:

1. This device may not cause harmful interference.
2. This device must accept any interference received, including interference that may cause undesired operation.

This equipment has been tested and found to comply with the limits for a Class B digital device, pursuant to Part 15 of the FCC Rules. These limits are designed to provide reasonable protection against harmful interference in a residential installation. This equipment generates, uses, and can radiate radio frequency energy and, if not installed and used in accordance with the instructions, may cause harmful interference to radio communications. However, there is no guarantee that interference will not occur in a particular installation. If this equipment does cause harmful interference to radio or television reception, which can be determined by turning the equipment off and on, the user is encouraged to try to correct the interference by one or more of the following measures:

- Reorient or relocate the receiving antenna.
- Increase the separation between the equipment and the receiver.
- Connect the equipment into an outlet on a circuit different from that to which the receiver is connected.
- Consult the dealer or an experienced radio/TV technician for help.

Shielded interconnect cables and shielded power cable must be employed with this equipment to insure compliance with the pertinent RF emission limits governing this device. Changes or modifications not expressly approved by the system's manufacturer could void the user's authority to operate the equipment.



Any changes or modifications not expressly approved by the party responsible for compliance could void the user's authority to operate the equipment.

This device is operable in 5.15 – 5.25GHz frequency range, then restricted in indoor use only, Outdoor operations in the 5.15 – 5.25GHz is prohibitive.

RF exposure warning

This equipment must be installed and operated in accordance with provided instructions and the antenna(s) used for this transmitter must be installed to provide a separation distance of at least 20 cm from all persons and must not be co-located or operating in conjunction with any other antenna or transmitter. End-users and installers must be provide with antenna installation instructions and transmitter operating conditions for satisfying RF exposure compliance.

CE Marking

This product has passed the CE test for environmental specifications when shielded cables are used for external wiring. We recommend the use of shielded cables. Please contact your local representative for ordering information.

This product has passed the CE test for environmental specifications. Test conditions for passing included the equipment being operated within an industrial enclosure. In order to protect the product from being damaged by ESD (Electrostatic Discharge) and EMI leakage, we strongly recommend the use of CE-compliant industrial enclosure products.

VIKING Conforms to the Following Specifications

LVD 2014/35/EU

EN 62368-1: 2014 +A11: 2017

EMCD 2014/30/EU

EN 55032

EN 55035

RED 2014/53/EU

- ETSI EN 300 328
- ETSI EN 301 893
- ETSI EN 300 330
- ETSI EN 303 413
- ETSI EN 301 489-1
- ETSI EN 301 489-3
- ETSI EN 301 489-17
- ETSI EN 301 489-19
- ETSI EN 301 489-52
- ETSI EN 301 511
- ETSI EN 301 908-1
- EN 62311

	BE	BG	CZ	DK	DE	EE	IE
	EL	ES	FR	HR	IT	CY	LV
	LT	LU	HU	MT	NL	AT	PL
	PT	RO	SI	SK	FI	SE	

RF Power Table

BT Maximum Conducted Power							
Ch.	BT-1M Freq.(MHz)	Data Rate	Target	Power Setting	Avg.(dBm)	EIRP (dBm) Tnom	EIRP Limit (dBm)
0	2402	1M	8.38	8.00	5.98	8.48	20
39	2441	1M	8.38	8.00	5.27	7.77	20
78	2480	1M	8.38	8.00	6.22	8.72	20
Ch.	BT-2M Freq.(MHz)	Data Rate	Target	Power Setting	Avg.(dBm)	EIRP (dBm) Tnom	EIRP Limit (dBm)
0	2402	2M	5.16	8.00	2.64	5.14	20
39	2441	2M	5.16	8.00	1.83	4.33	20
78	2480	2M	5.16	8.00	3.95	6.45	20
Ch.	BT-3M Freq.(MHz)	Data Rate	Target	Power Setting	Avg.(dBm)	EIRP (dBm) Tnom	EIRP Limit (dBm)
0	2402	3M	5.19	8.00	2.65	5.15	20
39	2441	3M	5.19	8.00	1.83	4.33	20
78	2480	3M	5.19	8.00	4.00	6.50	20

BLE Maximum Conducted Power

Ch.	BLE-1M Freq.(MHz)	Data Rate	Target	Power Setting	Avg.(dBm)	EIRP (dBm) Tnom	EIRP Limit (dBm)
0	2402	1M	3.10	default	1.64	4.14	20
19	2440	1M	2.57	default	0.79	3.29	20
39	2480	1M	2.16	default	1.61	4.11	20
Ch.	BLE-2M Freq.(MHz)	Data Rate	Target	Power Setting	Avg.(dBm)	EIRP (dBm) Tnom	EIRP Limit (dBm)
0	2402	2M	2.66	default	1.58	4.08	20
19	2440	2M	2.09	default	0.77	3.27	20
39	2480	2M	1.77	default	1.59	4.09	20

2.4GHz Conducted result

Ch.	802.11 b Freq.(MHz)	Data Rate	Target	Power Setting	Avg.(dBm) chain A	Avg.(dBm) chain B	Avg.(dBm) Total	EIRP (dBm) Tnom	EIRP Limit (dBm)
1	2412	1 Mbps	16.38	14/14	13.76	12.94	16.38	18.88	20
7	2442	1 Mbps	16.38	14/14	13.42	13.15	16.30	18.80	20
13	2472	1 Mbps	16.38	14/14	13.55	13.18	16.38	18.88	20
Ch.	802.11 g Freq.(MHz)	Data Rate	Target	Power Setting	Avg.(dBm) chain A	Avg.(dBm) chain B	Avg.(dBm) Total	EIRP (dBm) Tnom	EIRP Limit (dBm)
1	2412	6 Mbps	16.38	14/14	13.33	12.76	16.06	18.56	20
7	2442	6 Mbps	16.38	14/14	13.18	12.74	15.98	18.48	20
13	2472	6 Mbps	16.38	14/14	13.01	12.93	15.98	18.48	20
Ch.	802.11 n20 Freq.(MHz)	Data Rate	Target	Power Setting	Avg.(dBm) chain A	Avg.(dBm) chain B	Avg.(dBm) Total	EIRP (dBm) Tnom	EIRP Limit (dBm)
1	2412	HT 8	16.38	14.5/14.5	13.39	13.00	16.21	18.71	20
7	2442	HT 8	16.38	14.5/14.5	13.08	12.95	16.03	18.53	20
13	2472	HT 8	16.38	14.5/14.5	13.35	13.30	16.34	18.84	20
Ch.	802.11 n40 Freq.(MHz)	Data Rate	Target	Power Setting	Avg.(dBm) chain A	Avg.(dBm) chain B	Avg.(dBm) Total	EIRP (dBm) Tnom	EIRP Limit (dBm)
3	2422	HT 8	16.38	14/14	13.59	13.11	16.37	18.87	20
7	2442	HT 8	16.38	14/14	13.58	13.12	16.37	18.87	20
11	2462	HT 8	16.38	14/14	13.46	13.21	16.35	18.85	20

5GHz Conducted result

Ch.	802.11 a Freq.(MHz)	Data Rate	Target	Power Setting	Avg.(dBm) chain A	Avg.(dBm) chain B	Avg.(dBm) Total	EIRP (dBm) Tnom	EIRP Limit (dBm)
36	5180	6 Mbps	18.36	18/18	14.23	15.53	17.94	21.64	23
64	5320	6 Mbps	18.36	18/18	14.38	15.59	18.04	21.74	23
100	5500	6 Mbps	18.36	19/19	13.96	16.06	18.15	21.75	23
140	5700	6 Mbps	18.36	17.5/17.5	13.71	16.44	18.30	21.90	23
Ch.	802.11 ac20 Freq.(MHz)	Data Rate	Target	Power Setting	Avg.(dBm) chain A	Avg.(dBm) chain B	Avg.(dBm) Total	EIRP (dBm) Tnom	EIRP Limit (dBm)
36	5180	VHT 0	18.36	18.5/18.5	14.59	15.96	18.34	22.04	23
64	5320	VHT 0	18.36	18.5/18.5	14.51	16.04	18.35	22.05	23
100	5500	VHT 0	18.36	19/19	13.84	15.97	18.04	21.64	23
140	5700	VHT 0	18.36	17.5/17.5	13.53	16.36	18.18	21.78	23
Ch.	802.11 ac40 Freq.(MHz)	Data Rate	Target	Power Setting	Avg.(dBm) chain A	Avg.(dBm) chain B	Avg.(dBm) Total	EIRP (dBm) Tnom	EIRP Limit (dBm)
38	5190	VHT 0	18.36	18/18	14.68	15.90	18.34	22.04	23
62	5310	VHT 0	18.36	18/18	14.70	15.89	18.35	22.05	23
102	5510	VHT 0	18.36	18.5/18.5	13.72	16.06	18.06	21.66	23
134	5670	VHT 0	18.36	17/17	13.30	16.12	17.95	21.55	23
Ch.	802.11 ac80 Freq.(MHz)	Data Rate	Target	Power Setting	Avg.(dBm) chain A	Avg.(dBm) chain B	Avg.(dBm) Total	EIRP (dBm) Tnom	EIRP Limit (dBm)
42	5210	VHT 0	18.36	18/18	14.44	15.70	18.13	21.83	23
58	5290	VHT 0	18.36	18/18	14.48	15.55	18.06	21.76	23
106	5530	VHT 0	18.36	18.5/18.5	13.57	15.96	17.94	21.54	23

Lithium Battery Safety Statement

Lithium battery inside. Danger of explosion if battery is incorrectly replaced. Replace only with the same or equivalent type of battery recommended by battery manufacturer.

Disposal of a BATTERY into fire or a hot oven, or mechanically crushing or cutting of a BATTERY, that can result in an EXPLOSION;

Leaving a BATTERY in an extremely high temperature surrounding environment that can result in an EXPLOSION or the leakage of flammable liquid or gas;

A BATTERY subjected to extremely low air pressure that may result in an EXPLOSION or the leakage of flammable liquid or gas.



THIS PRODUCT CONTAINS LITHIUM-ION BATTERY PACKS. IT MUST BE
DISPOSED OF PROPERLY. CONTACT LOCAL ENVIRONMENTAL
AGENCIES FOR INFORMATION ON RECYCLING AND DISPOSAL PLANS IN YOUR
AREA.

Chapter 1. Product Introduction

VIKING is an in-vehicle terminal with 7" high resolution display and 500nits brightness, and is flexible to support a wide range of wireless connection capability. The device is well-suited for fleet management, asset management, EOBR and ELDs application.

It is compliant to ISO 7637-2, SAE J1455 and SAE J1113 and its optimized power system is designed for cold cranking, load dump, transient voltage and ESD.

The device is engineered with IP65 protection rating, a wide temperature design, wide input range, and rich expanding interfaces that support in-vehicle connectivity.

Hardware Specifications

Item	Description
Processor	Qualcomm® Snapdragon™ 660 Octa-Core, up to 2.2GHz
Memory	3GB LPDDR4 SDRAM
Storage	32GB eMMC, Micro SD slot x 1
Display	<ul style="list-style-type: none"> ● 7" TFT LCD WSVGA (1024 x 600), , 500 nits brightness ● Viewing angel: 145(H)/ 160(V) (CR>10) ● Support auto-dimming
Touch Panel	<ul style="list-style-type: none"> ● Capacitive multi touch (PCT)
Wireless Connectivity	<ul style="list-style-type: none"> ● GNSS (GPS / GLONASS / BeiDou/ Galileo), optional dead-reckoning support ● 4G LTE / WCDMA / GSM, Dual SIM Dual Standby ● IEEE 802.11ac 2x2 MU-MIMO ● Bluetooth V5.0 ● RFID/ NFC
Item	Description
Power Input	9-36VDC,3.5A
Battery	1950mAh, 3.6V
Housing (Mechanical)	PC+ABS, fanless design
Certification	CE, FCC, CB, E-Mark

Environment

- Operating temperature:
 - -20°C (-4°F) to 60°C (140°F)
 - In accordance with MIL-STD-810H Method 501.7 High Temperature Procedure II - Operation
 - In accordance with MIL-STD-810H Method 502.7 Low Temperature Procedure II - Operation
- Storage temperature:
 - -30°C (-22°F) to 70 °C (158°F)
 - In accordance with MIL-STD-810H Method 501.7 High Temperature Procedure I - Storage
 - In accordance with MIL-STD-810H Method 502.7 Low Temperature Procedure I - Storage
- Relative humidity: 5% to 95% @ 30°C (86°F) to 60°C (140°F) non-condensing in accordance with MIL-STD-810H Method 507.6 Humidity Procedure II Aggravated Cycles
- Vibration Test:
 - Operating: MIL-STD-810H Method 514.8 Category 4,
Fig 514.8C-2 Common carrier (US highway truck vibration exposure);
Fig 514.8C-4 Composite two-wheeled trailer;
Fig 514.8C-6 Composite wheeled vehicle.
 - Operating: IEC 60721-3-5 Class 5M3
 - Non-Operating: MIL-STD-810H Method 514.8 Category 24 Figure 514.8E-1
General minimum integrity
- Shock Test:
 - Operation: MIL-STD-810H Method 516.8 Procedure 1 Functional Shock
 - Non-Operation: MIL-STD-810H Method 516.8 Procedure V Crash Hazard Shock

I/O Ports

Item	Description
Serial	RS-232 x 1 with 0/5/12V support 0.6/0.3A (COM1) - Data rate Max. 250kbps RS-232 TX, RX/422/485 x 1 (COM2) - RS-232 data rate Max. 250kbps - RS-422/485 data rate Max. 250kbps
USB	USB 2.0 type A x 1 USB 2.0 x 1 (COM2) USB 3.1 type C x 1 (DisplayPort Alt Mode supported)
Ethernet	Gigabit Ethernet (RJ45) x 1
Digital I/O	DI x 2, DO x 2
CAN	Raw CAN bus, or CAN bus module (supports SAE J1939) - High Speed Max. 1 Mbit/s
Audio	Audio headset jack x 1 Internal MIC-in x 2
Speaker	Waterproof speakers 2W

Dimension and Weight

VIKING Standard

Dimension: 219.98 x 151.98 x 40.80 (mm) / 8.66 x 5.98 x 1.61 (in.) (W x H x D)

Weight: 1.25 kg/ 2.76 lbs.

Front View Dimension

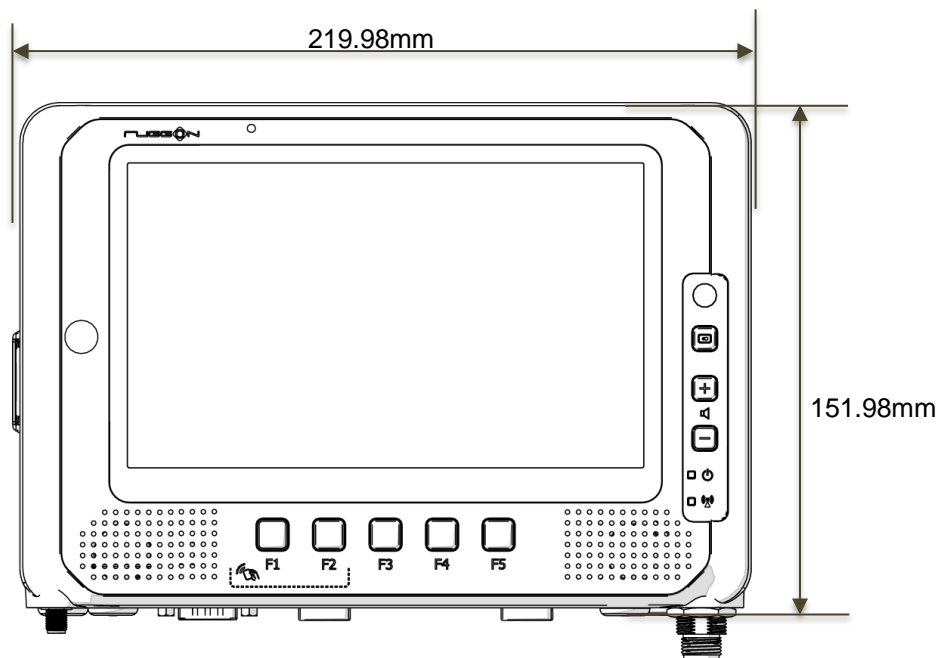

Side View Dimension

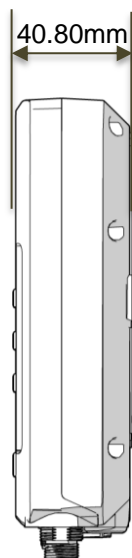

Package List

Before you begin the installation or configuration process, make sure to inspect all the components and accessories. Contact your representative if there are any missing or damaged items.

Please verify the delivery of the contents upon receipt

- VIKING in-vehicle terminal
- Quick Start Guide
- 2M Power cable with fork terminals

NOTE: The packaging material has been selected to optimally protect your device. After unpacking, store the original packaging material in the event that you need to return for shipment.

Chapter 2. Hardware Installation

This chapter provides information for the installation and removal of SIM card

Installing/Removing the SIM card

The device provides dual micro SIM slots for cellular and wireless connection. One is accessible from external SIM cover (SIM1) and the other is inside (SIM2).

You can either Install SIM card in external or internal SIM slot and this selection can be done via SIM slot assignment in Android setting. The factory default is the external SIM slot.

Please see the following guidelines to install or remove the SIM card.



Please make sure that the device is completely powered off and make sure the power status LED light is off when installing/removing the internal SIM card.

Internal SIM slot (SIM2)

1. Shut down the system properly and disconnect the device from all power sources.
2. Un-mount the device from the mounting apparatus; make sure that the display surface is protected.
3. Remove the screws securing the cover.

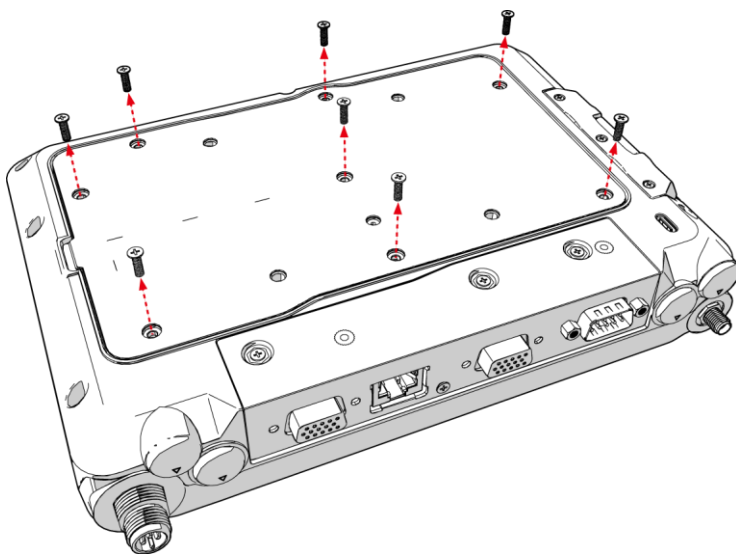

4. Remove the cover.

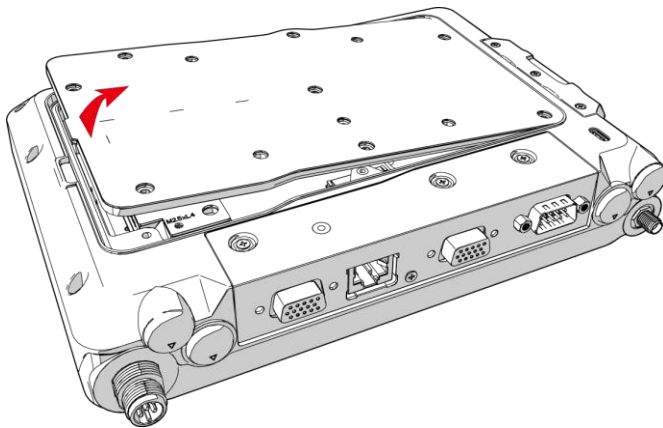

5. Once the service cover is removed, you can see the micro SIM card slot (SIM2).

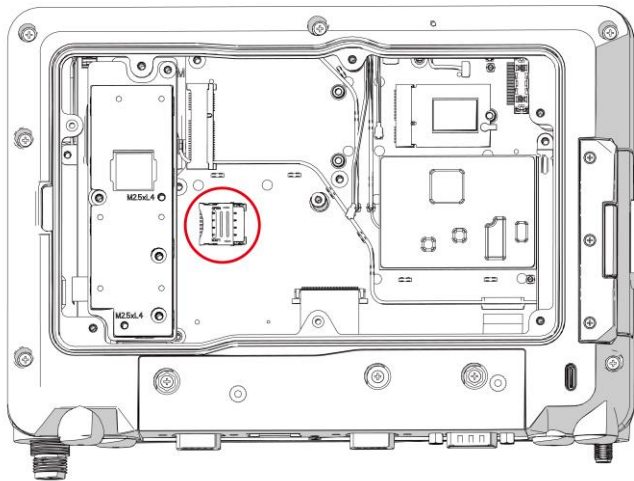

6. To release the SIM card holder, slightly lift the front edge of the cover on the card holder and slide it backwards. Open the cover.

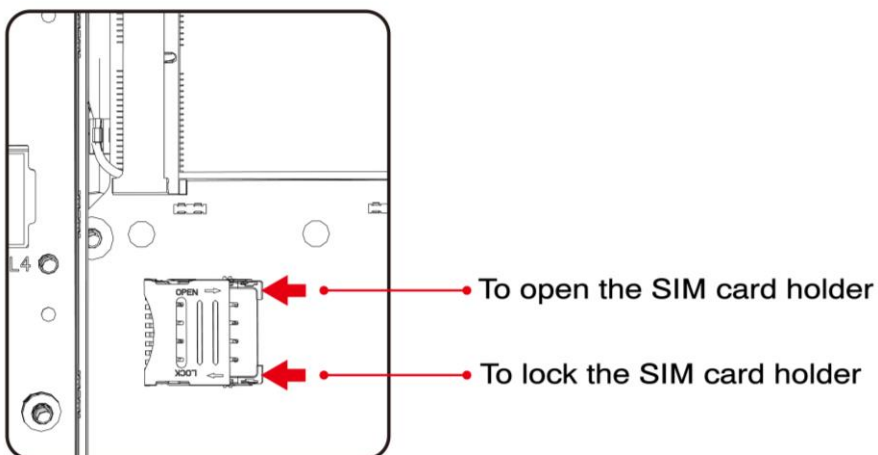

7. Turn your SIM card to the angled corner of your SIM card to match the angled corner of

the SIM card holder.

8. Insert the SIM card into the SIM card holder.
9. Close the cover of the SIM card holder.

External SIM slot (SIM1)

1. Shut down the system properly and disconnect the device from all power sources.
2. Open the side cover; you can see the micro SIM card and SD card slot.

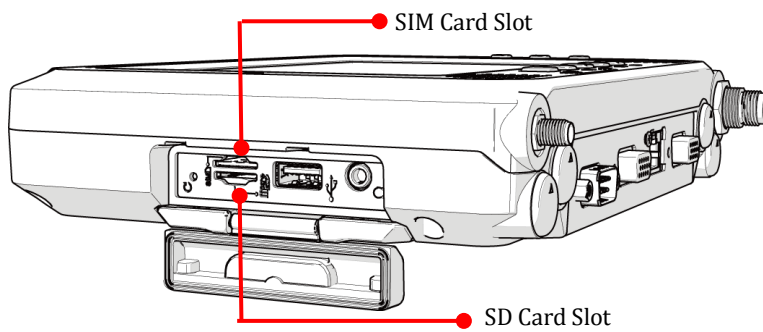

3. Insert your SIM card. Make sure the angled corner of the card is positioned correctly.

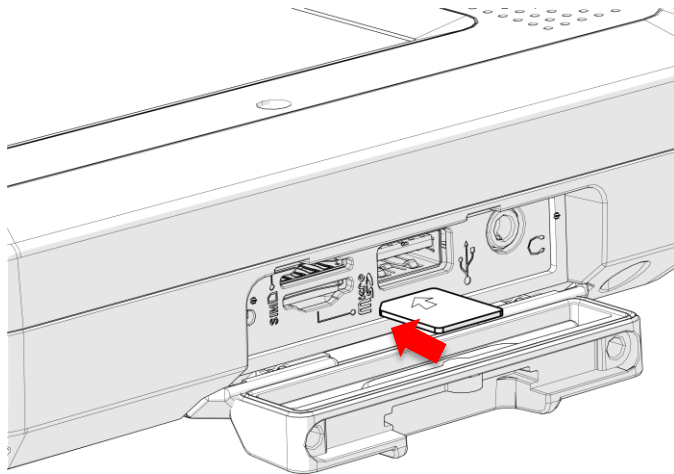

Chapter 3. Hardware Mounting

The VIKING supports a standard VESA version MIS-D, 75, C (75mm distance quadrate order, M5 thread, deepness 6mm) through the four drill holes on the back side of the device.

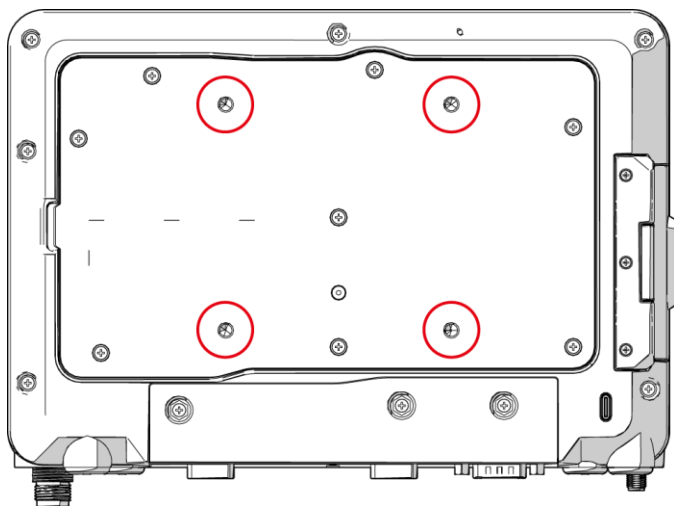

Notes: *To prevent any damage or injury, make sure the mounting bracket is securely attached.*

Chapter 4. Start up

Powering the System

Installation Instructions

Fuses are required in connecting the power cable and battery in series and add 3A fuse in ACC/ignition line to avoid the risks of wire damage and vehicle burning.

Notes:

5A for 24VDC power input

10A for 12VDC power input

Please refer to the diagram below for VIKING installation.

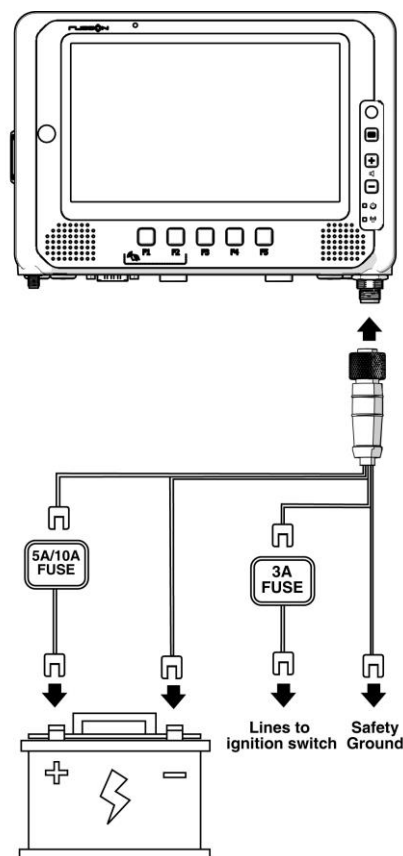

Connector Power

VIKING allows a wide range of DC power input from 9~36V via a 5-pin M12 A-code power cord. There are two options to start up the VIKING, either via car power cable or external power adapter.

Here is the 5-pin M12 A-code power cord.

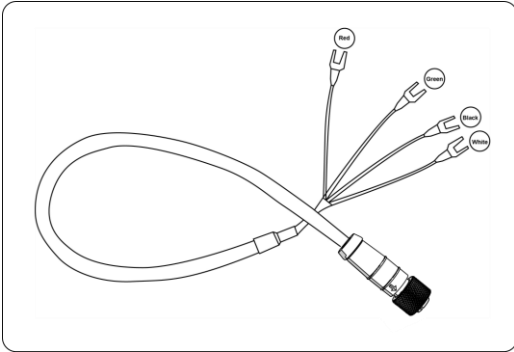

1. Use only power cables verified and supplied by RuggON to meet the specific requirements for voltage, current, low-temperature flexibility, UV resistance, oil resistance, etc.
2. Do not bend or kink the power supply cables and make sure they are securely protected against crushing and abrading.
3. Make sure power cables are correctly connected to the safety ground
4. Directly connect the power cable to vehicle battery through appropriate fuse instead of sharing any power supply lines of other equipment to avoid interference.
5. To compensate the voltage drop of the power supply cable, make sure that it is left with adequate cross-section area for sufficient ampacity.

The wire definition

Wire Color	Description
RED	V+
BLACK	V-
GREEN	PE (Safety Ground)
WHITE	ACC/ Ignition

Power source from car power cable

1. The bare wire lead cable allows you to directly wire 12 V or 24 V car power supply.
Please follow the wire definition to connect to your power source.
Please refer to the installation diagram on page 20 to install the 5A or 10A fuse between the power cable and power source.
2. Plug the power code into the power connector on the top of the arrow mark.

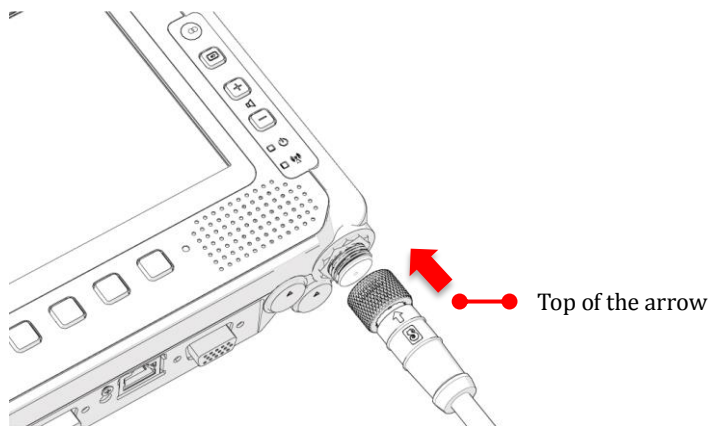

3. Twist the nut to lock the power connector to the device.

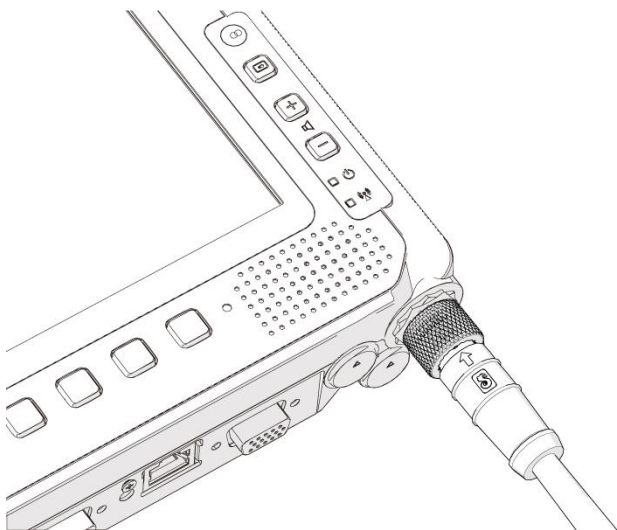

4. VIKING will turn on automatically when ACC is switched ON. If you use software to power off the system, to turn on the VIKING you need to press and hold down the power button at least for 3 seconds.

Power source from external power adapter

If your power source is from external power adapter, it means the power source isn't controlled by AAC/Ignition signal. Please short red (V+) and white (ACC/ Ignition) wires.

VIKING will turn on automatically when power is connected.

If you use software to power off the system, to turn on the VIKING you need to press and hold down the power button at least for 3 seconds.



Make sure that all the power supplies are disconnected when you plug the power cord into the power connector.

Please press the power button to turn off the system. If you direct remove the power source, the system will consume UPS battery instead and perform a graceful shutdown in one minute. It will reduce the battery life

Backup Battery

The purpose of internal backup of VIKING is for graceful shutdown or sustain the system for seconds in conditional mode while the external power supply is suddenly removed or gone. This internal battery is not to sustain the system running in the normal mode. After the external power supply is gone, the system running is shift to the mode below until it complete the shutdown or the external power resume.

- (1) Type-C interface disable
- (2) Lateral side USB disable
- (3) Turn off the COM1 power output
- (4) Backlight is forcibly turned dark

When the external power is in presence, an internal charger will automatically charge the backup battery. The ratio of the internal battery charged time against its discharged time is around 5 times. It means it takes 5 minutes to charge the battery after discharging the battery for 1 minute.

Powering Down the System

When VIKING is connected to vehicle battery

- When system is on, switch the ignition from on to off to turn off or delay off the system.
- When system is on, press the power button to turn off the system. To turn on the VIKING you need to press and hold down the power button at least for 3 seconds.

When VIKING is connected to power adapter

When system is on, press the power button to turn off the system. To turn on the VIKING you need to press and hold down the power button at least for 3 seconds.

Unexpected Power Outage

The system will follow your delay off setting first, and then perform a graceful shutdown up to six minute.



Please press the power button to turn off the system. If you direct remove the power source, the system will consume UPS battery instead and perform a graceful shutdown in one minute. It will reduce the battery life

LED Status

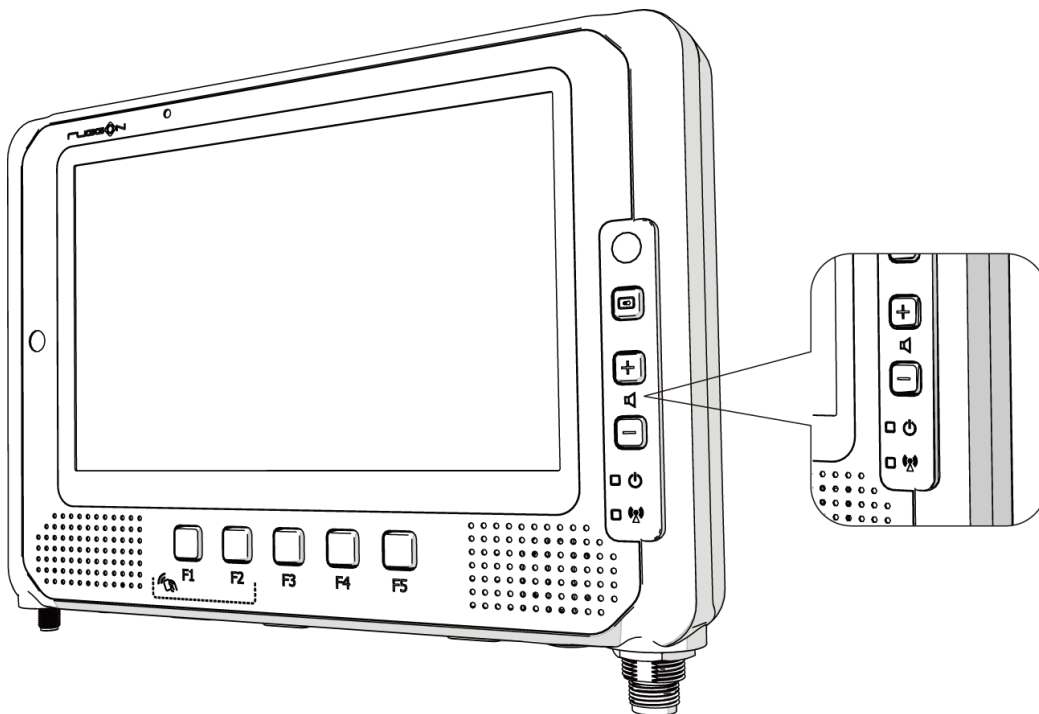

The LEDs on VIKING are status indicators that show the operating status of your system. The status indicators can help pinpoint possible failed hardware components causing specific symptoms. There are two status indicators in the front panel. Refer to the description below.

LED	Status	Description
Power	Blink Green	Power up
Power	Blink Yellow	Load boot loader
Power	Solid Green	System ready for use
Power	Blink Red	Vehicle battery abnormal
Communication	Solid Green	WWAN enabled



Adjust the Speaker Volume

VIKING provides the volume control buttons to adjust the speakers' volume; you can also control the overall level of sound using Android Setting. When you press the top part of the volume button, it makes the volume louder; pressing the bottom part makes the volume lower

- Press the  button to increase the volume.
- Press the  button to decrease the volume.

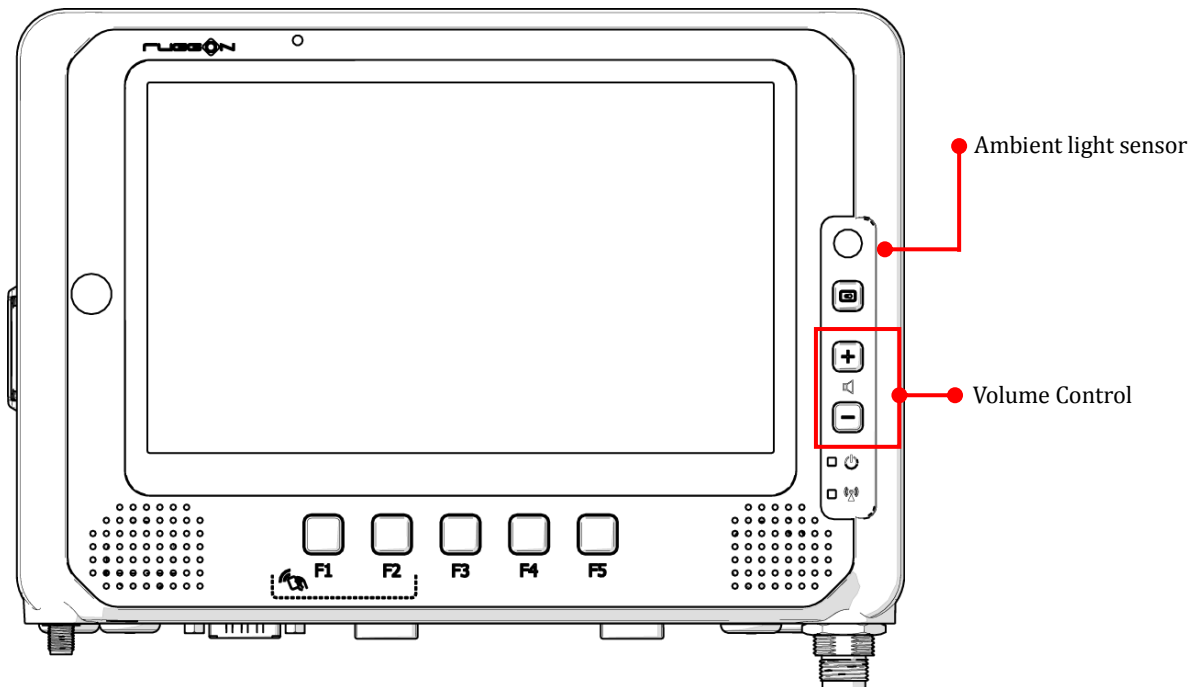

Auto-Brightness Adjustment

When you use VIKING, you may well encounter different lighting conditions that make it difficult to see the information on screen. VIKING's built-in ambient light sensor on the front panel supports auto-dimming, which you can also disable to manually adjust the screen's brightness; this setting can be done via Android Setting.

Internal Microphone

VIKING is equipped with 2 internal microphones (one at the front and the other at the rear) for better audio reception, so you don't need an external one. In addition to the built-in speaker and microphones, you can plug external headsets in the audio jack.

Programmable Buttons

VIKING provides default commands for five programmable buttons. You can configure the programmable buttons via Android Setting to different commands or keyboard shortcuts to better fit your work style.

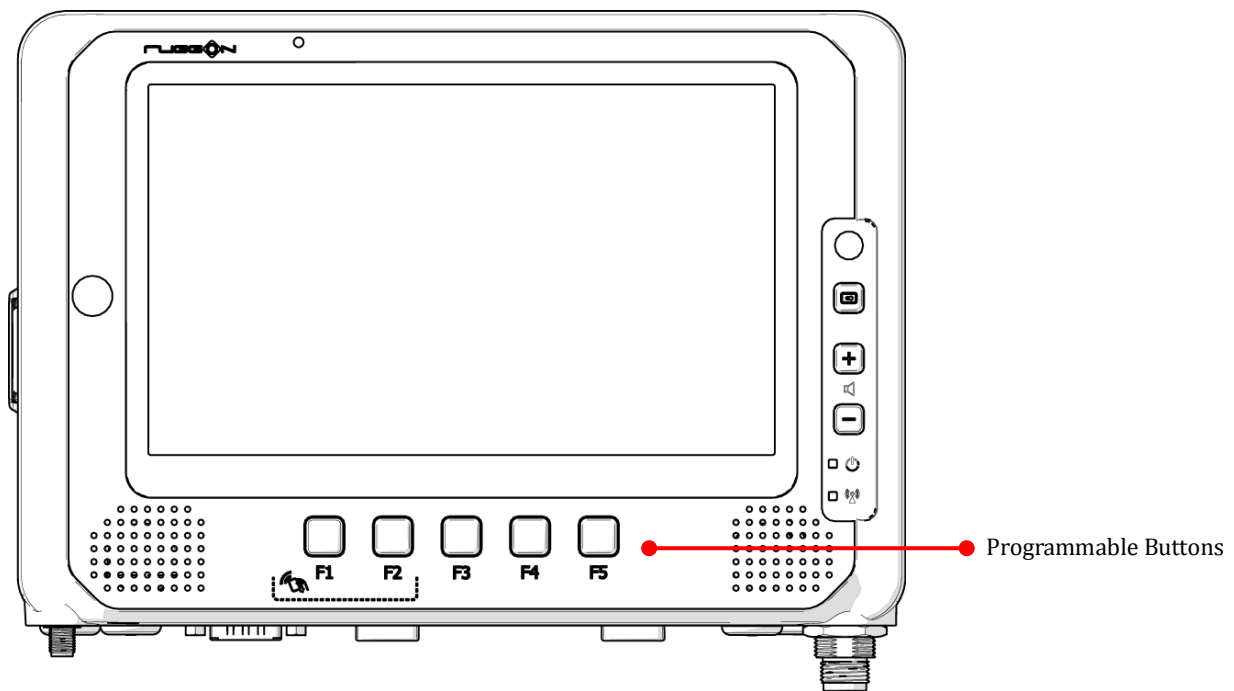

Power Management

VIKING provides Android Setting for configuration which includes power management and system setup.

Chapter 5. Jumpers and Connectors

Bottom View

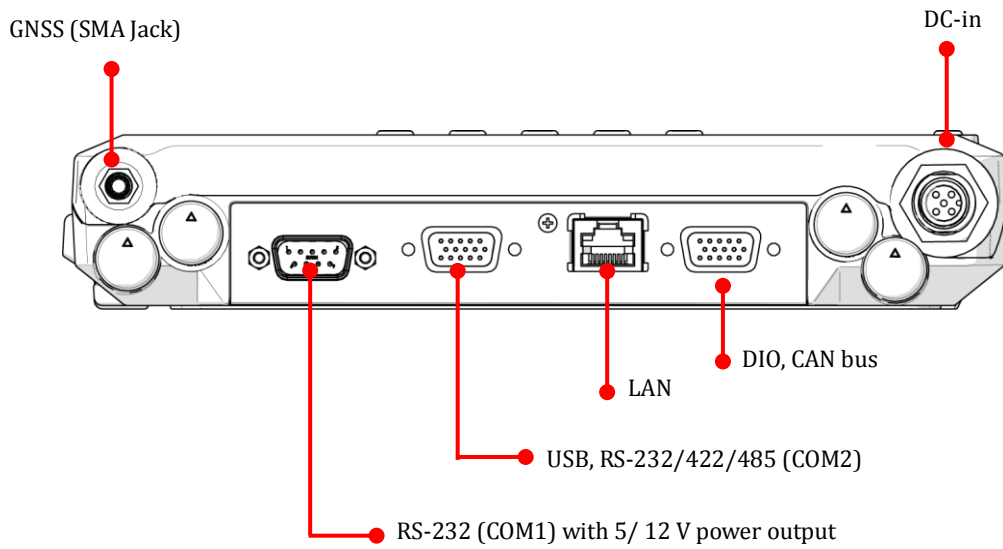

External Connectors Pin Assignments

Use this section as a reference for the pin assignments of the various ports available on the VIKING.

Power Connector

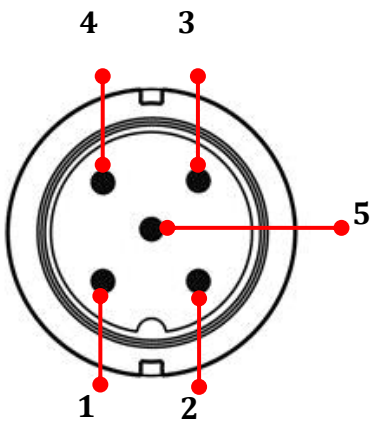

Pin	Description
1	DC+
2	DC+
3	GND
4	GND
5	ACC/ Ignition

Note: Please refer to section 1 in Chapter 4 for connecting the external power cable to power source.

RS-232 Port (COM1)

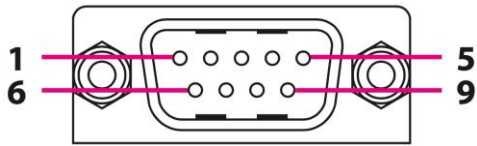

Pin	Signal	Description
1	DCD	Data carrier detect (input)
2	RXD	Receive data (input)
3	TXD	Transmit data (output)
4	DTR	Data terminal ready (output)
5	GND	Signal/power ground
6	DSR	Data set ready (input)
7	RTS	Request to send (output)
8	CTS	Clear to send (input)
9	PWR	12V/300mA or 5V/600mA

USB and RS-232/422/485 Port (COM2)

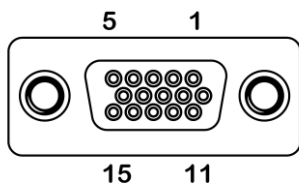

Pin	Signal
1	RS-422 TX+
2	RS-422 RX+
3	RS-485 TX+
4	RS-232 TX
5	GND
6	RS-422 TX-
7	RS-422 RX-
8	RS-485 TX-
9	USB 5V
10	RS-232 RX
11	GND
12	USB DP
13	USB DM
14	USB 5V
15	NC

We provide Y-cable with DB15 male connector which is the RS232/422/485 and USB converter. Please contact your local sales representative for ordering information

RS-232/422/485 and USB Cable

This Y-cable with DB15 male connector is the RS232/422/485 and USB converter. The other end of this Y-cable contains one USB type A jack for USB2.0 and one DB9 male connector for RS232/422/485. If you like to use RS232 or RS422 or RS485, please refer to the pin definition below.



Cable Drawing

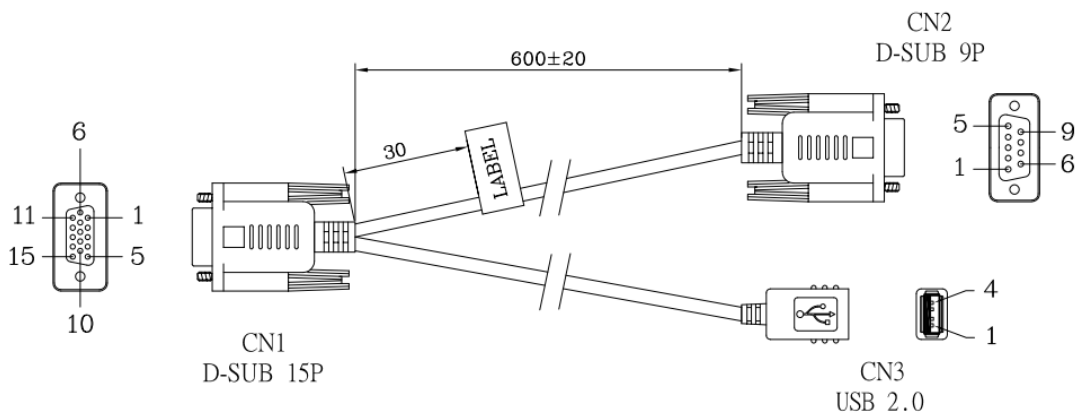

Pin Definition of DB9 (CN2) connector:

Pin	Signal	Pin	Signal
1	RS-422 TX-	6	RS-485 TX+
2	RS-232 RX	7	RS-422 TX+
3	RS-232 TX	8	RS-422 RX-
4	RS-422 RX+	9	RS-485 TX-
5	GND		

Digital I/O and CANbus Port

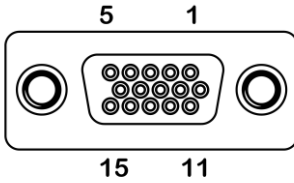

Pin	Signal
1	CAN_H
2	N/A
3	N/A
4	ISO_GND
5	N/A
6	CAN_L
7	N/A
8	N/A
9	N/A
10	N/A
11	SOS
12	DIO_OUT1 (5V, Max 5mA)
13	DIO_IN1 (5V, Max 15mA)
14	DIO_IN2 (5V, Max 15mA)
15	DIO_OUT2 (5V, Max 5mA)

We provide the DB15 male connector to multiple pins without termination cable. Please contact your local sales representative for ordering information

Chapter 6. Technical Support

We provide the Partner Zone for technical documents information; please contact your sales representative to authorize the use of the RuggON Partner Zone.